

TECHNICAL NOTE

GLT80TDC



COMPRESSORS FOR MOBILE REFRIGERATION
for cabin truck air conditioning and refrigerators
GLT80TDC · R134a



cubigel[®]
compressors

by
HUAYI
COMPRESSOR
BARCELONA

GLT80TDC 24-42V DC

The solution for high demands of cooling capacity for cabin truck air conditioning and refrigerators



The GLT80TDC is Cubigel Compressors®' cooling solution for trucks where a high demand of cooling capacity is needed it for either DC powered air conditioner utilised at sleeping cabinets and for mobile refrigerators.

GLT80TDC is compact in its dimensions, highly reliable and yield high performances. It is designed to operate silently, efficiently and reliably even up to angles of tilt of 20°, and works with refrigerant R134a. Its design is based on Cubigel Compressors®' "L" series, which has been successfully presented in the market since 1964, and has had sales of millions of units.

The specific design of this compressor includes internal transport stoppers which enhances the compressor's reliability in front of the specific working conditions which are carried out on mobile applications in the road.

Its high efficiency mechanics and its brush-less motor together with its variable speed drive feature make the cabinet which assembles this compressor a very efficient appliance from the energy consumption point of view.

GLT80TDC Main Advantages and Benefits

- Biggest DC reciprocating compressor in the market (8.1 cc displacement).
- Not remote electronic drivers needed. The already included electronic driver is enough to power and control the compressor.
- Prepare to operate silently, efficiently and reliably even up to angles of tilt of 20°.
- Speed self-adaptation to the real cooling need by means of the Smart Speed® feature.
- Built-in protections: against battery discharge, fan over-current, starting failure, compressor overload and electronic driver overheat.
- Wide working range: from -25°C to +10°C evaporating temperature range.
- Compatible with the Huayi Compressor Barcelona FxC programming software.
- Compressor able to work up to 43°C ambient temperature.

Smart Speed® feature

The electronic control unit FDC3 is supplied with the exclusive Serial Port Interface (SPI), featuring a RJ45 telephone type connector. SPI allows the electronic driver to be connected to a computer for programming purposes using the FxC programming package (hardware and software, provided by Huayi Compressor Barcelona under request), and allows the communication with an Electronic Integral Manager of the appliance (EIM), and making the compressor work in slave mode.

FDC3 electronic driver includes Smart Speed® as programming option, which is a plug-in system for automatically self-adapting compressor speed to current thermal load in refrigerating appliances.

Smart Speed® reduces number of thermostat cycles by minimizing compressor speed, enlarging on-time at every thermostat cycle, so that start/stop energy losses are substantially reduced. Lowest speed yields also highest evaporating

temperature, and so highest C.O.P. and lowest energy consumption. Pull-down is done at maximum programmed speed, so pull-down time is very short with respect to fixed speed systems. No design parameters neither of the compressor nor the appliance are required to be programmed, so Smart Speed® can be easily used in all appliances with no design efforts.

FDC3 electronic driver includes Sleep and Sleep Energy Saving as programming option, which are plug-in systems specially conceived for mobile air conditioners avoiding any other electronic device. Sleep and Sleep Energy Saving make the air conditioner work for four hours since start-up. Sleep Energy Saving makes the compressor run at maximum programmed speed during the first hour, when highest cooling capacity is needed, and lowers progressively the compressor speed up to minimum velocity three hours later. Maximum comfort and minimum energy consumption are thus achieved.

Smart speed functioning when higher cooling capacity is needed.

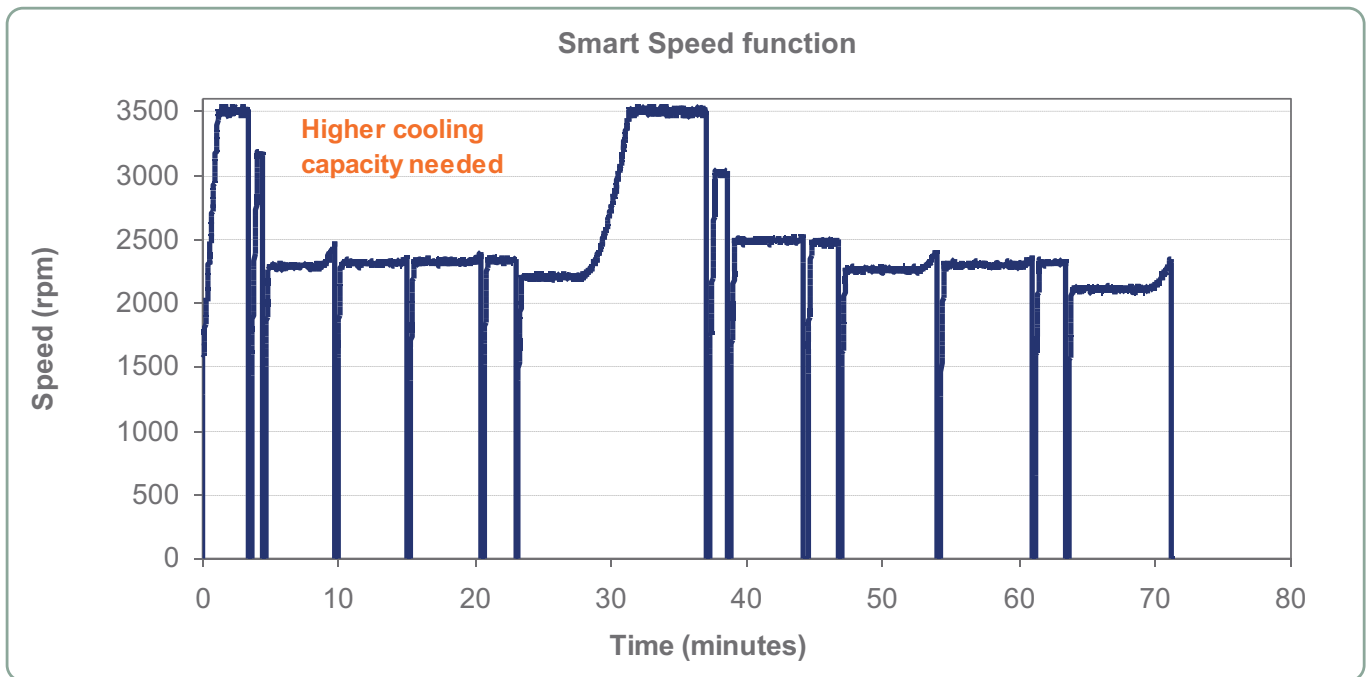

The figure shows how the speed of the compressor changes when higher cooling capacity is needed. This situation may happen in a cabin truck application when the door of the cabin is open or when ambient temperature from outside gets higher. As soon as the electronic driver detects that time-on during current cycle is longer than during the previous cycle, the speed is gradually increased till arriving to the max speed (if needed) in order to cool down the temperature inside the cabin as soon as possible. This behavior is also applicable in a mobile refrigerator when a warm load is added or in any other situation where the cooling need in that specific cycle is higher than in the previous one.

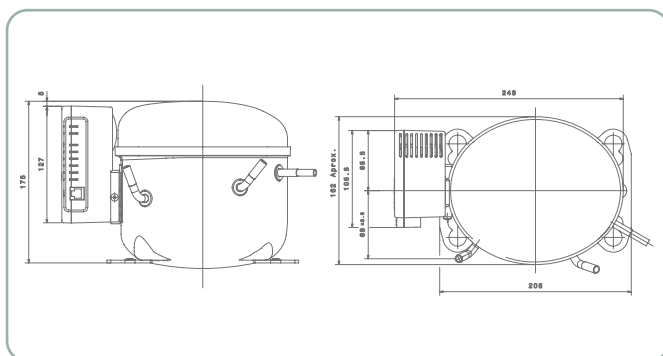

Figure n°2. GLT80TDC 24-42V dimensions

NOTE:
Smart Speed® mode: Compressor operates at variable speed at its highest performance depending on the current thermal load. The maximum speed can be limited by a fixed programmed.

GLT80TDC main technical characteristics	
Displacement:	8.1 cc
Gas:	R134a
Application:	HMBP (from -25°C to +10°C evaporating temperature range)
Compressor motor:	Brush-less, sensor-less, flexible speed
Supported devices:	12V DC Fan Compressor speed level switcher Alarm LED 5V/25mA Electronic Integral Manager
Speed range:	1500 ÷ 3500 rpm
Expansion system:	Capillary
Compressor cooling:	Fan
Max. ambient temp.:	43°C
Communication port:	Serial Port Interface
Comm. Capabilities:	Bidirectional serial port type UART 2-digit, 4-level switcher Alarm LED
Speed selection:	By programming or switching
Protections:	Supply voltage out of limits Fan over current Starting failure Compressor overload Electronic driver overheat
Programmable modes:	Standard, Smart Speed®, Night, Night Energy Saving, Slave Mode

Rated performances data of the GLT80TDC 24-42V in function of the speed.

GLT80TDC 24-42V DC compressor performances

Condensing temperature 55°C | Liquid temperature 46°C | Suction temperature 35°C | Ambient temperature 35°C | Test voltage 24V DC

Cooling Capacity (kcal/h) in function of evaporating temperature

rpm	-25°C	-10°C	+7,2°C
1500	72	168	369
2000	100	228	497
2500	123	285	613
3000	145	341	725
3600	166	392	834

C.O.P. (W/W) in function of evaporating temperature

rpm	-25°C	-10°C	+7,2°C
1500	1,05	1,41	2,19
2000	1,15	1,64	2,34
2500	1,13	1,62	2,26
3000	1,11	1,58	2,17
3600	1,09	1,54	2,07

Input Power (W) in function of evaporating temperature

rpm	-25°C	-10°C	+7,2°C
1500	80	139	196
2000	101	162	247
2500	127	205	315
3000	152	251	388
3600	177	296	468

Current consumption (A) in function of evaporating temperature

rpm	-25°C	-10°C	+7,2°C
1500	3,33	5,75	8,17
2000	4,21	6,75	10,30
2500	5,29	8,50	13,10
3000	6,33	10,50	16,20
3600	7,38	12,30	19,50



**HUAYI
COMPRESSOR
BARCELONA**

Huayi Compressor Barcelona, S.L.

Antoni Forrellad, 2 · 08192
Sant Quirze del Vallès · BCN · Spain
Phone: +34 93 710 60 08
Fax +34 93 710 69 58

www.huayicompressor.es